

Performance Specifications

RATIO:	1:1
MAX. G.P.M. (LPM):	170 (644)
DISPLACEMENT GALLONS (Liters) PER CYCLE:	1.4 (5.3)
AIR INLET:	3/4" NPTF (f)
AIR EXHAUST:	1-1/2" X 11 NPTF (f)
FLUID INLET:	2" NPTF (f), BSP (f) or Flange
FLUID OUTLET:	2" NPTF (f), BSP (f) or Flange
MAX. OP. PRESSURE PSI (bar):	120 (8.3)
PASS SOLIDS MAX. DIA. IN. (mm):	1/4 (6.4)
WEIGHT LBS. (Kgs.):	64 (29) Aluminum
MAX. DRY SUCTION LIFT:	19 ft. (Rubber fitted)

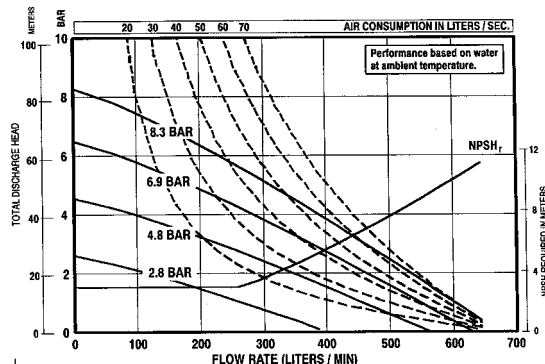
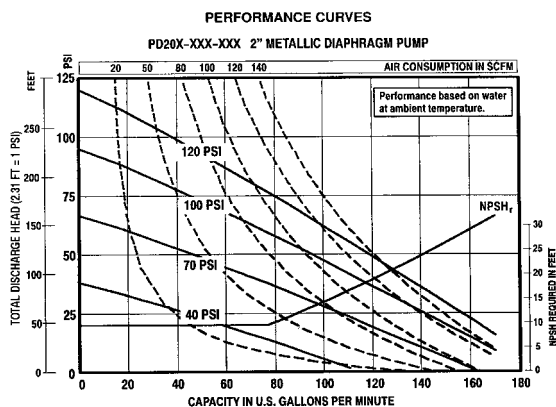

Dimensional Data

Air Motor Muffler **Now Included!** (Muffler Dimensions Not Shown)

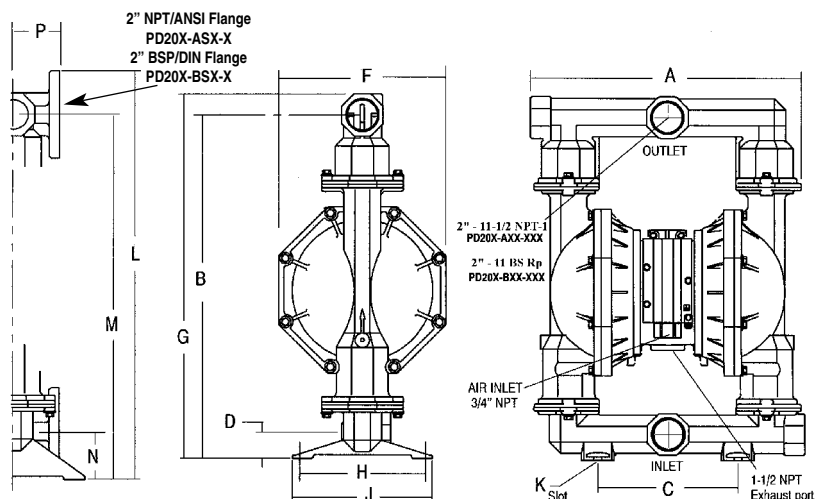

DIMENSIONS

A 19-3/4" (502 mm)	F 12" (305 mm)	L 28-5/8" (727 mm)
B 24-3/4" (629 mm)	G 26-1/4" (667 mm)	M 25-5/8" (651 mm)
C 10-1/16" (256 mm)	H 9-1/16" (230 mm)	N 3-3/8" (86 mm)
D 1-7/8" (48 mm)	J 10-1/16" (256 mm)	P 2-1/4" (62.5 mm)
	K 9/16" (14 mm)	

Accessories

Recommended Filter-Regulator
(See Page 49)

Filter / Regulator: P29241-610

For complete airline connection kit, see page 32, item "B".
Pulsation Dampener, see page 34.



P29241-610

For Diaphragm Pump Accessories see pages 33-34.



Screened Inlet Kits Available. See Page 27.

Ordering

Best Selling Models | PD20A-AAP-AAA, PD20A-AAP-GGG, PD20A-AAP-KTT, PD20A-AAP-STT

Base Model	Center Section	Port	Wetted End	Hardware	Seat Material	Ball Check/ Diaphragm
P D 2 0	X	X	X	X	X	X X X
2" Pump	A Aluminum	A NPT	A Aluminum	P Plated Steel	AA Santoprene/Santoprene GG Nitrile/Nitrile TT Teflon®/Teflon	
				A Santoprene G Nitrile K Kynar (PVDF) S 316 St. Steel		

The most advanced process pump on the market.

